

EF-CBD130

Conventional reflective beam detector



EF-CBD130 is a versatile reflective beam detector for use with the Eaton range of conventional fire systems. Alignment is made easy with a built in laser pointer and digital display.

The laser pointer is used to mark the exact location where the reflector is to be installed. Once the reflector is installed the digital display indicates the light intensity between the detector and the reflector enabling the user to adjust for optimal alignment.

To meet the requirements of multiple applications the EF-CBD130 has four adjustable distance ranges three sensitivity settings.

This product is designed to replace individual point detectors in large open areas, such as warehouses, and requires a separate power supply unit. Fire and fault conditions are signalled to the panel using standard zone wiring, so no additional interconnections are required.

Features and benefits

- EN54-12
- Intuitive alignment with built in laser pointer and digital display
- Four range modes
 - 8 to 20m
 - 20 to 40m
 - 40 to 70m
 - 70 to 100m
- Three sensitivity settings
 - 2.6dB High Sensitivity
 - 3.8dB Medium Sensitivity
 - 5.8dB Low Sensitivity
- Adapts to the environment; Automatic compensation for weakened signal caused by building movement or gradual build up of dust



Powering Business Worldwide

Technical specification:

Code	EF-CBD130
Description	Reflective beam detector
Standards	EN54 Pt12
Specification	
Operating voltage	18 to 30VDC
Quiescent current	23mA
Alarm current	33mA
Alignment current	56mA
Operating range	1 x reflector 8 to 40m 4 x reflector 40 to 100m
Beam Sensor Sensitivity	High 2.6dB Medium 3.8dB Low 5.8dB
Beam Path Angle	±0.4° Directional (This data takes the average of the left and right deflection angles.)
Alignment Guide	Laser Beam Pointer
Digital Display Guide	Nixie Tube
Reset Time	Red: Fire ; Yellow: Fault ; Green: Alignment
LED Indicator Guide	Laser Beam Pointer
Relay Capacity [Fire & Fault]	Normally Open & Closed 2.0A; 30VDC
Environmental	
Operating temperature	-10°C to +50°C
Humidity (non condensing)	0 to 95% RH
Physical	
Construction	ABS
Colour	White
Dimensions	L:190.87 x W:126.87 x H:91.96 mm
Weight	0.44kg
Ingress protection	IP30 [IP66 glue seal-For permanent fixing, Not EN54-12 approved]
Compatibility	
Suitable for use with	Eaton conventional fire systems

Dimensions

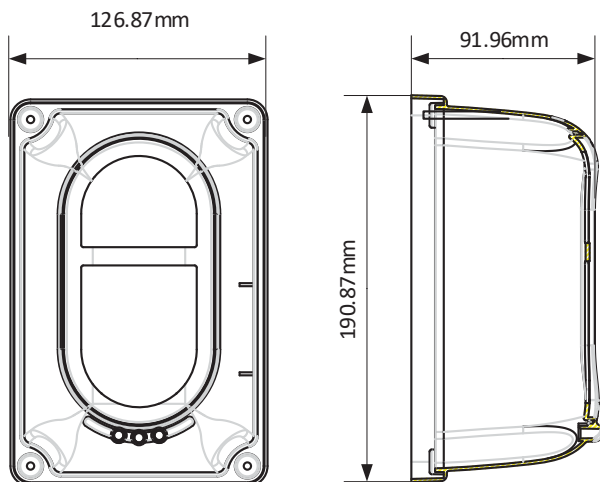

Example wiring configuration

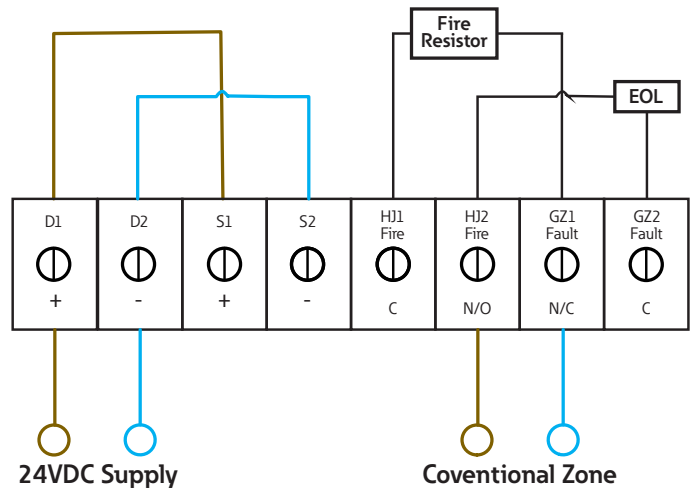

Catalogue numbers

Product description	Model reference	Order codes
Conventional reflective beam detector (EN 54)	EF-CBD130	EF-CBD130

Further information

Please refer to the EF-CBD130 manual and connection guide for further details.

The product is supplied with four reflectors, a mounting bracket, a testing card and a magnetic commissioning tool.

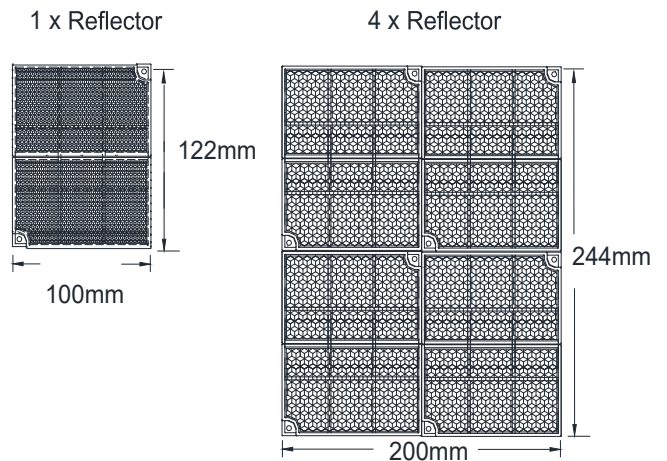

Eaton Electrical Products Ltd.
Llantarnam Park
Cwmbran
NP44 3AW
Tel: +44 (0) 1633 628500
Fax: +44 (0) 1633 866346
www.eaton.com

© 2022 Eaton
All Rights Reserved
August 2022 DS0044-A

Note: All information correct at the time of writing. Eaton reserve the right to make changes to this information. Please contact Eaton if you have any queries.

Eaton is a registered trademark.

All other trademarks are property of their respective owners